

MPR 15 - XG

MPR 15 PLATFORM

PROVISIONAL DATASHEET [BAUMA10]



BUILDING WITH CONFIDENCE.

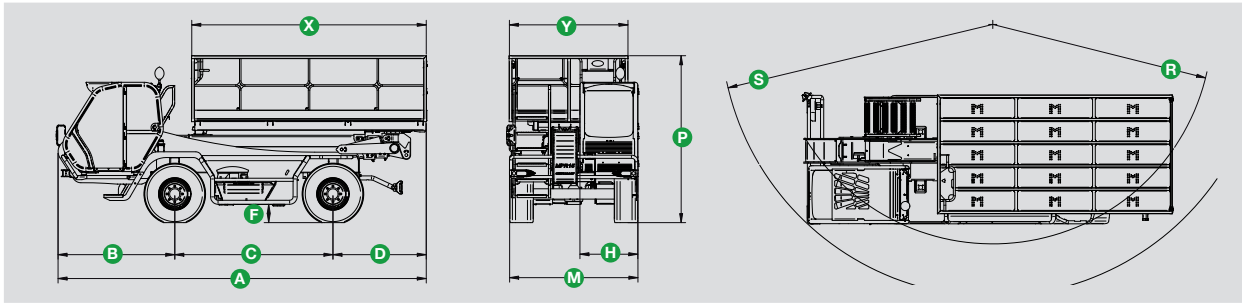

▲ Integrated design of all components leads to incomparable compactness of the MPR 15. The ease of handling and precise positioning, together with a lively engine, give exceptional manoeuvrability.

A (mm)	6300
B (mm)	2000
C (mm)	2760
D (mm)	1540
F (mm)	320
H (mm)	2240
M (mm)	995
P (mm)	2920
R (mm)	3800
S (mm)	4750
X (mm)	4000
Y (mm)	2000

▼ The Platform MPR 15 can drive upon the roads with complete autonomy at up to **40 kph** (where national regulations permit), driven from a fully furnished operator's cab. Once upon a worksite, control is transferred to the basket also with the boom raised at up to full working height.

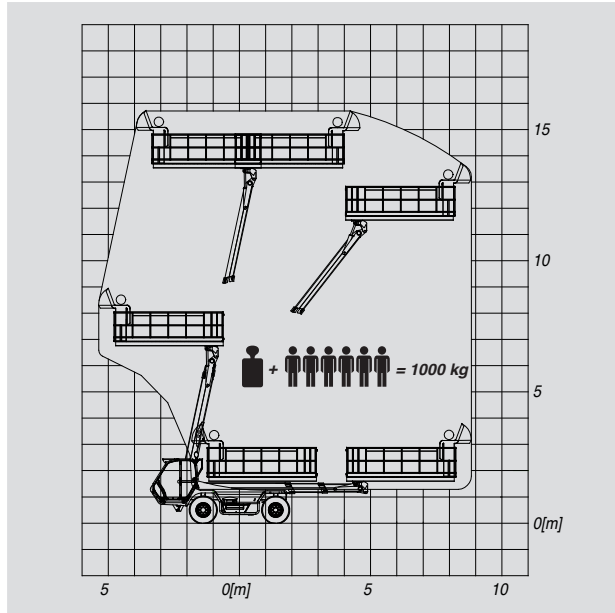

▲

Operating weight (kg)	10800
Max lift capacity (kg)	1000
Max lift height (m)	15.6
Max forward reach (m)	8.800
Capacity at full height (mm)	1000
Platform slew (deg)	550
Speed in 1st gear (kph)	11
Speed in 2st gear (kph)	40